

# INSTRUCTION MANUAL

**SATURN™  
MODEL AV-190**

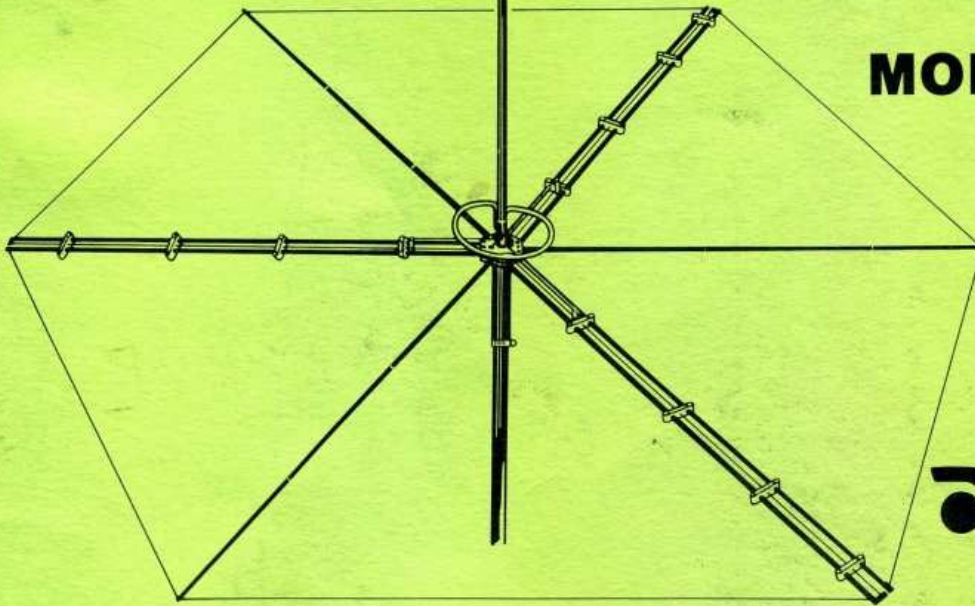

**avanti®**



**SATURN AV-190**

**PARTS LIST**

<b>PART NO.</b>	<b>QUANTITY PER ANTENNA</b>	<b>DESCRIPTION</b>	<b>PRICE RETAIL EACH</b>
1010	1	1/2" Cap Plug	.15
1051	2	1-3/4 S.S. Clamp	.60
1060	9	5/8 S.S. Tube Clamp	.30
1090	39	1/4 -20 Hex Nut	.06
1091	13	10-32 Hex Nut	.06
1092	4	5/16-18 Hex Nut	.06
1151	32	#10 Ext. Star Washer	.06
1152	60	1/4" Flat Washer	.06
1153	40	1/4" Ext. Star Washer	.06
1156	4	5/16 Ext. Star Washer	.06
1186	6	1/4 -20 x 3/4" Bolt	.11
1189	35	1/4 -20 x 1 1/2 Bolt	.11
1195	13	10-32 x 1/2" Screw	.11
1469	7	3/8-16 Hex Nut	.11
1511	3	1" S.S. Tube Clamp	.55
1783	2	5/16 x 5" U-Bolt	1.00
1979	3	Balun Bracket	1.10
1981	3	3/8 D-Bolt	.70
1982	9	Spacer Bushing	.20
1983	1	Hub Lock Cam Cone	.95
1984	1	Hub Lock	4.00
1985	1	Hub Lock Bolt	1.45
1986	3	Wire Clamp Sleeve	.80
1987	3	Wire Clamp Stud	.90
2540	2	U-Bolt Retaining Bars	.50
2541	2	H-Bracket	.60
PS 060	1	Mast Support Tube	6.00
PS 063	3	5/8" Separator Clamp	4.45
PS 064	6	3/4" Separator Clamp	4.45
PS 065	3	1/2" Separator Clamp	4.45
SUB 244	6	Peripheral Wire	1.00
SUB 245	3	Balun Wire	.90
SUB 130	2	Loop Sections	1.20
SUB 107	1	Switchbox	12.95
SUB 241	1	Static Arrestor Assembly	3.70
PS 030	1	1-1/4 x 36 Bottom Rad. Sect.	6.30
SUB 263	1	Hub with Connector	13.75
SUB 265	1	Hardware Bag	44.50
1523	1	1-1/8 x 36 Radiator Sect.	4.20
1524	1	1 x 36 Radiator Sect.	4.20
1525	1	7/8 x 48 Radiator Sect.	4.20
1526	1	3/4 x 48 Radiator Sect.	4.20
1749	10	5/8 x 36 Alum. Element	4.20
1992	9	3/4 x 48 Horizontal Element	4.20
1993	6	1/2 x 32 Horizontal Element	1.80
1994	3	1/2 x 28-1/2 Horizontal Element	1.80
2518	3	Feed Rod 1/4" x 24"	2.00
2539	1	Alum. Hub	12.50
2724	1	1/2 x 36" Vert. Radiator Sect.	1.80
1520	1	Water Seat Boot	.90
2624	1	Fiberglass Insulator Tube	13.15
2630	1	Instruction Manual	.00





# FACT SHEET

U.S. CONSUMER PRODUCT SAFETY COMMISSION  
WASHINGTON, D. C. 20207

## NO. 88: ANTENNA ELECTROCUTIONS

The U.S. Consumer Product Safety Commission has received reports of several electrocutions that occurred when metal antennas — radio, television, and citizens' band radio — touched overhead power lines. At the time of the accident, the victim was holding the metal antenna for installation or removal, and the electric current flowed from the power line through the conductive metal to the victim.

The following example shows how such an accident can occur:

DON CLIMBED UP A METAL LADDER TO HIS ROOF CARRYING A TV ANTENNA HE WAS GOING TO INSTALL. AS HE REACHED THE TOP OF THE LADDER, A STRONG WIND BLEW THE TOP OF THE ANTENNA HE WAS HOLDING INTO THE POWER LINE LEADING INTO THE HOUSE, AND DON WAS ELECTROCUTED.

Most residential power lines carry in excess of 2000 volts A.C. to transformers located in residential areas. The wires that carry electricity from these transformers to houses carry 240 to 120 volts A.C. Any of these quantities of electrical current are powerful enough to kill.

Many persons mistake high voltage electrical power lines for relatively low voltage telephone lines, since both are strung on poles. Power lines are usually 18-25 feet above ground in residential areas. Since the power and telephone wires may be difficult to distinguish, *avoid touching ANY wires going above or into your house.*

Don't assume power lines are insulated; most high voltage wires are not insulated. In addition, weathering and years of use can cause any insulation to degrade, peel or crack, and therefore not offer effective protection against shock.

High voltage power lines or the lines going from the transformer into the house can shock a person who is electrically grounded (i.e., directly or indirectly in contact with the earth to which all electricity flows) if he touches the wires with a metal object. The following conditions, however, *increase* the likelihood of electrocution and should be avoided:

1. *Moisture.* Wet or sweaty feet and hands, in particular, decrease the body's resistance to electric current. To provide better insulation against shock, wear rubber boots or rubber-soled shoes when working around power lines.
2. *Metal.* Touching a grounded metal ladder or gutter while holding an antenna against a power line turns the body into an excellent path for electrical current. The current can flow from the power line to the antenna, through the body, through the metal ladder or gutter, and finally to ground. Metal ladders 20 to 30 feet high also can inadvertently touch overhead power lines and provide a path for the electricity to flow through the person holding the ladder. It is suggested that you use wooden or fiberglass ladders when working around electrical wires.
3. *Wind.* The wind can blow the antenna into a nearby power line. Don't install or remove antennas in moderate or heavy winds.

### EMERGENCY AID FOR SHOCK

It is advisable to work with another person when installing or removing antennas. If your partner does receive a shock, don't touch him since his body could conduct the electricity to you; instead, try to pry or pull him away from the source of electricity with a length of dry wood, rope, a blanket, or another non-metallic object.

If breathing has stopped, use mouth-to-mouth resuscitation until the doctor or ambulance arrives and relieves you. If the heart has stopped, closed-chest cardiac massage must be done simultaneously. The ambulance should be informed when called that an electric shock has occurred; it can bring proper equipment such as an intensive care or cardiac care mobile unit equipped with a heart defibrillator and carrying trained personnel.

## IMPORTANT SAFETY NOTICE

This AVANTI base station antenna is designed to be D.C. (Direct Current) grounded to the support mast using the mounting hardware provided. Proper grounding of the support mast can provide a considerable amount of lightning protection for the radio equipment. Grounding of the mast can

also "bleed off" static preventing any buildup. Be sure your antenna mast tripod or tower are properly grounded. Consult the National Electrical Code, local building codes, your local CB dealer or antenna installation experts for installing a good, safe ground on your antenna.



## PRELIMINARY NOTE

Before starting the assembly of this antenna, a brief description and a few tips may result in saving construction time and insure good performance.

The mast must be supplied by the user and since this antenna has two methods of mounting, understanding this will enable the user to make the proper choice to fit his installation.

This antenna can be mounted directly on a mast which measures exactly 1.500 inches outside diameter. It simply slides over the mast and is secured with a tube clamp supplied.

The other method is to side mount the antenna to your mast. Your mast size may range from 1-1/2 inches to 1-3/4 inches. The necessary hardware to do this is also supplied.

1-1/4 inch galvanized water pipe is often used. The outside diameter of this pipe is 1.660 inches, so the second method would have to be used.

For dual polarity operation, this antenna requires

two coax lines. The vertical polarity coax will be attached to the connector on the hub while the horizontal is attached inside the mast support tube.

In the first method, the horizontal coax will be inside the full length of mast with the vertical coax taped to the outside of the mast.

Both of these coax lines are fed to a switchbox located by the radio. By this means, the operator is able to select either horizontal or vertical polarization.

With the second, the side mount method, both coax lines must be taped to the outside of the mast.

As with any antenna, the choice of good quality coax is important. Tests have been conducted in our engineering laboratory involving coax cable. The results were that if some of the economy brands were used, the low S.W.R. that this antenna is capable of, would be lost.

### STEP 1

There are nine identical 3/4 inch tubes, 48 inches long with a hole in one end.

Take these nine tubes and sandwich them between the two hub halves. (See note and Fig. 1)

Fasten together with nine 1/4 inch bolts, 1-1/2 inches long; put a flatwasher under the head of each bolt and a starwasher under each nut.

**NOTE:** The main hub consists of two halves. The bottom half is the one which contains the coax connector and a 5/8 hole adjacent to it. The top half contains two 5/8 holes only.

The hub sections must be oriented so that one 5/8 hole in the top section lines up with the 5/8 hole in the bottom section.

The wire jumper from the coax connector in the bottom must be fed through the remaining 5/8 hole in the top section.

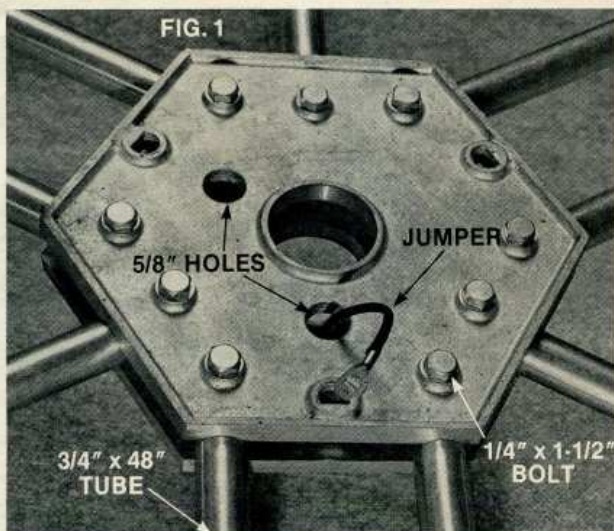

### STEP 2

Locate the hub lock. Notice that the hole in it is tapered. Slide the hub lock between the two hub halves by the 5/8 holes that are in line. (Fig. 2)

The side with the largest diameter of the tapered hole in the hub lock must face up.

Position the concave radius of the lock toward the large center hole of the hub.

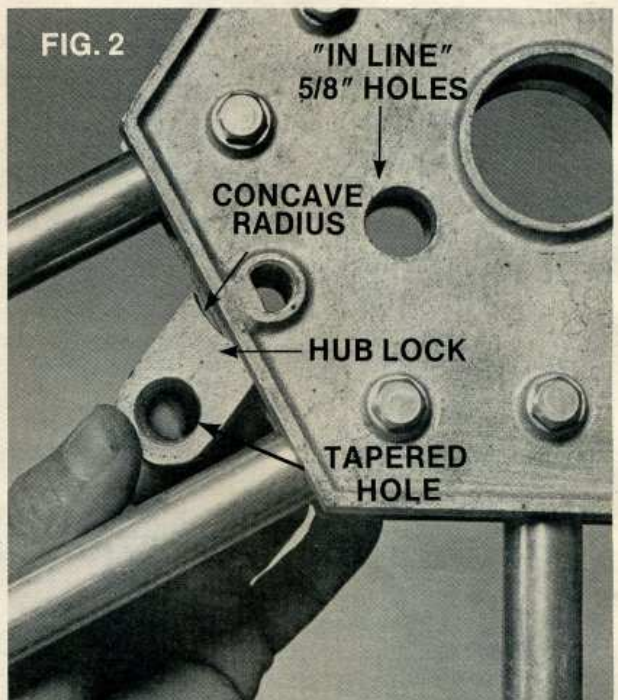



### STEP 3

Starting from the bottom on the hub, pass the hub lock bolt through the 5/8 hole, then through the tapered hole of the hub lock and through the 5/8 hole in the top hub section. (Fig. 3)

The hub lock bolt must be inserted far enough into the hub that the shoulder of the bolt is into the 5/8 hole of the bottom hub section.

### STEP 4

Slide the cam cone onto the hub lock bolt, the small end of the cone pointing toward the hub. (Fig. 3)

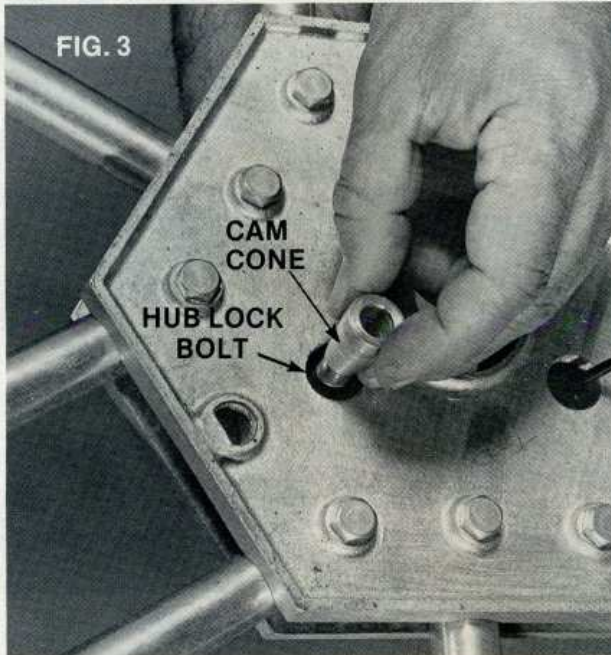

### STEP 5

Start a 3/8 nut onto the exposed threads of the hub lock bolt. Screw nut on only one or two turns. (Fig. 4)

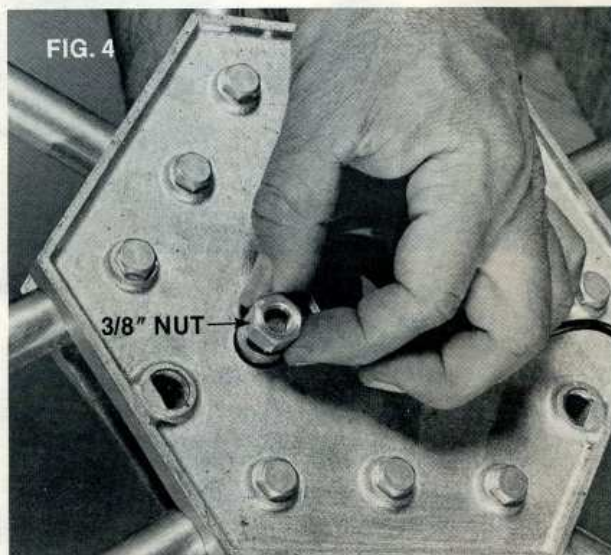

### STEP 6

Insert the small end of the mast support tube into the large center hole of the hub. For ease of assembly, turn the entire assembly up-side down. Push in until the shoulder of the tube strikes the hub. (Fig. 5)

NOTE: The hub lock may interfere with the insertion of the support mast tube. If so, loosen the nut (Fig. 4) as far as possible without removing it and pull the cam cone up against the nut.

While holding the cone against the nut, push the hub lock away from the center hole, then insert the mast tube as described.

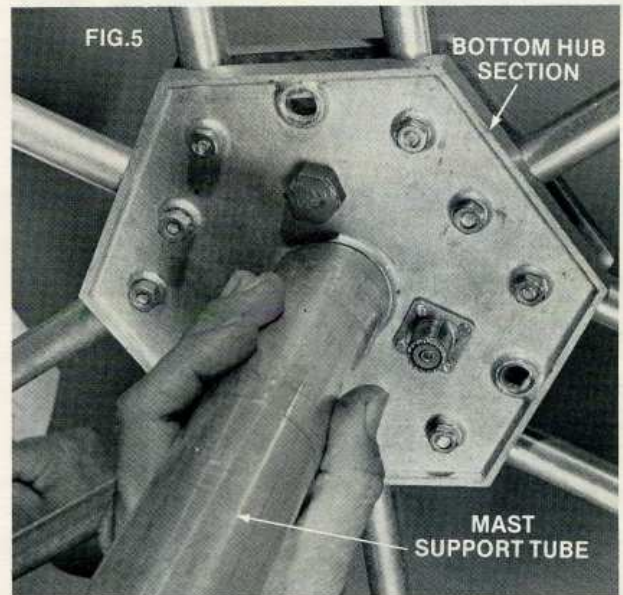

CAUTION: The concave radius of the hub lock must match the radius of the support tube.

It is possible for the hub lock to turn without the support tube installed, so hold the hub lock in position with your finger until the support tube is inserted. (Fig. 6)

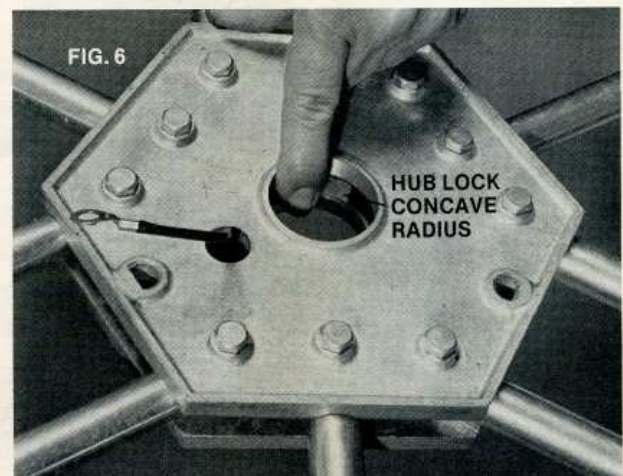



### STEP 7

The mast tube is locked to the hub by tightening the nut on the hub lock bolt. (Fig. 4) However, temporarily it should only be tightened enough to keep the mast tube from falling out, because the tube must be repositioned in a later step. Turn the assembly right side up again.

### STEP 8

Install the three terminator bolts as follows:

- A. Take two spacer bushings, one stacked on top of the other and place them between the hub sections right by one of the three "D" Holes. (Fig. 7)
- B. Pass a terminator bolt through the top hub section, through both spacer bushings and through the bottom hub section.
- C. Install a 3/8 nut, finger tight only. (Fig. 8)
- D. Install the remaining terminators identically.

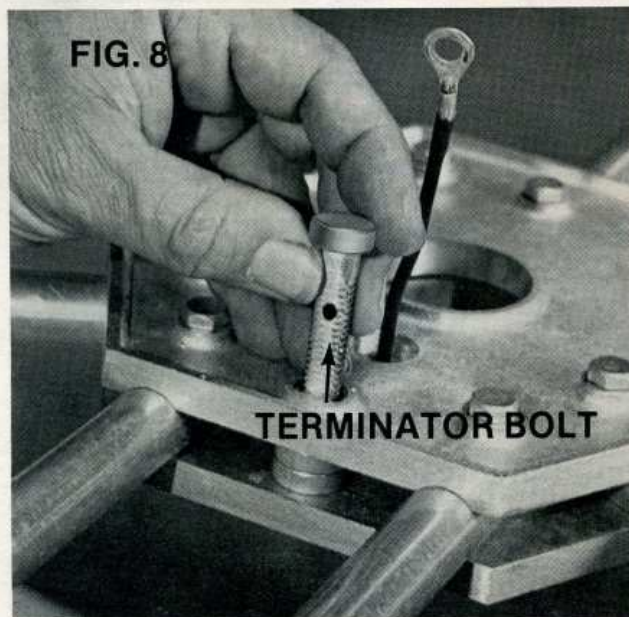
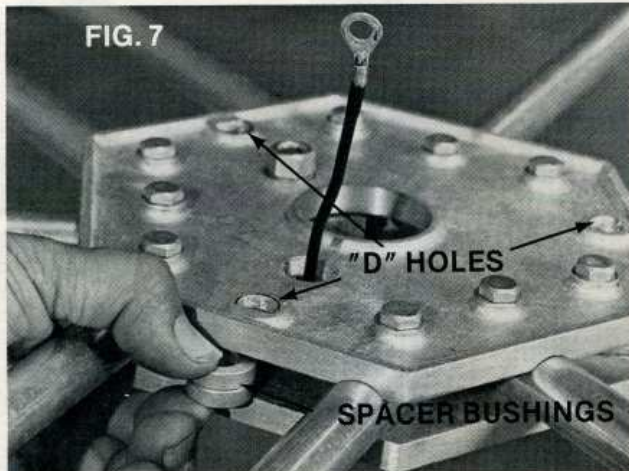

### STEP 9

There are 12 separator clamps:

- 6 of them are 3/4 inch;
- 3 of them are 5/8 inch; and
- 3 of them are 1/2 inch.

Slide a 3/4 inch separator clamp on each pair of 3/4 inch Balun arms protruding from the hub. (Fig. 9)

Install hardware as shown and loosely fasten 20 inches from the hub. Place a flatwasher under the head of each bolt. Put a flatwasher and starwasher under each nut.

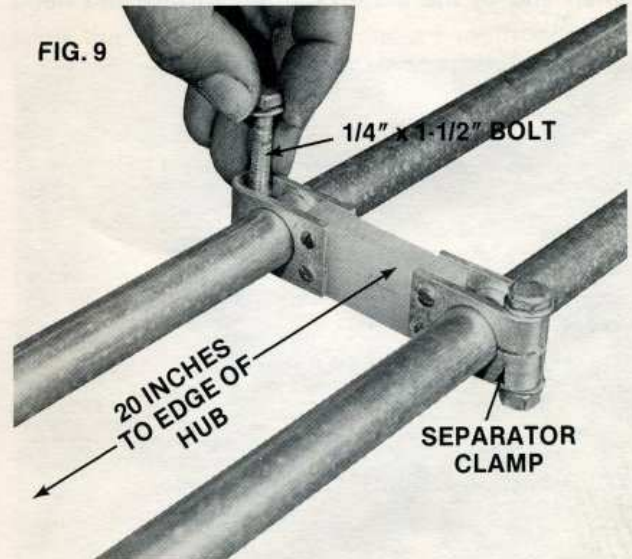

### STEP 10

Install the remaining three 3/4 inch separator clamps at the tips of each pair of 3/4 inch Balun arms (over the slots). (Fig. 10)

Install hardware as in Step 9. Do not tighten.

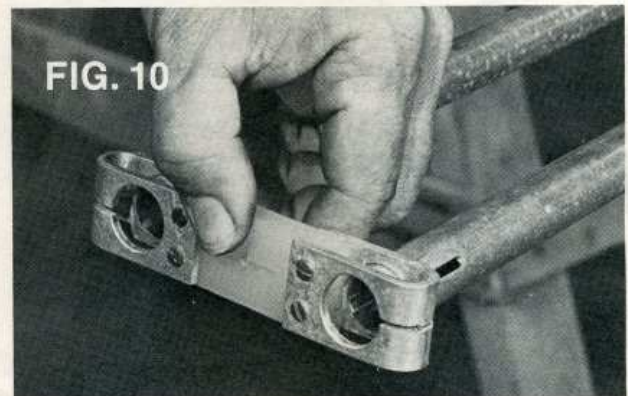

### STEP 11

Put a small tube clamp over each of the three 3/4 inch spreader arms, over the tip slots. Do not tighten. (Fig. 11 & 12)

NOTE: Place the tube clamps on the spreader arms only, not the Balun arms. See Fig. 12 to determine which three arms are the spreader arms.



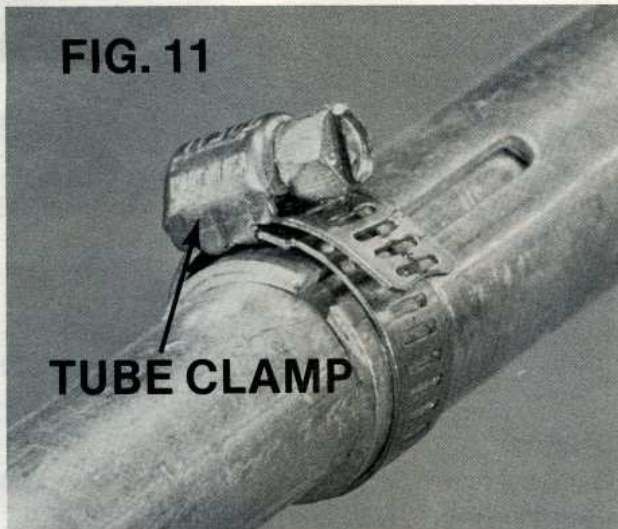

**FIG. 11**

**TUBE CLAMP**

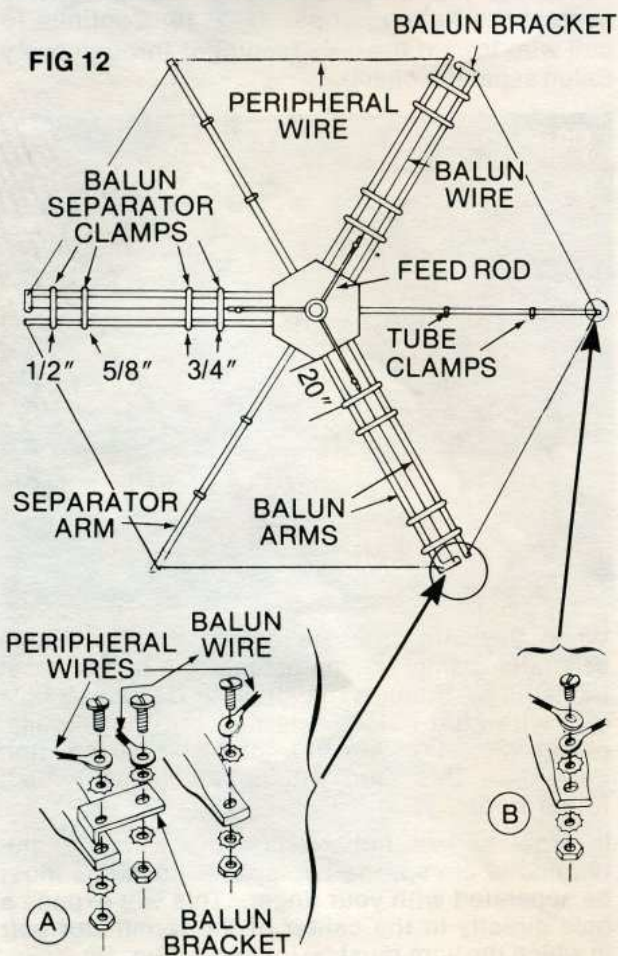

Slide the unslotted end of a 5/8 inch tube into each 3/4 inch arm. (There are nine arms.) (Fig. 13 & 11)

All 5/8 tubes must be inserted in up to the dimple. Do not force beyond the dimple.

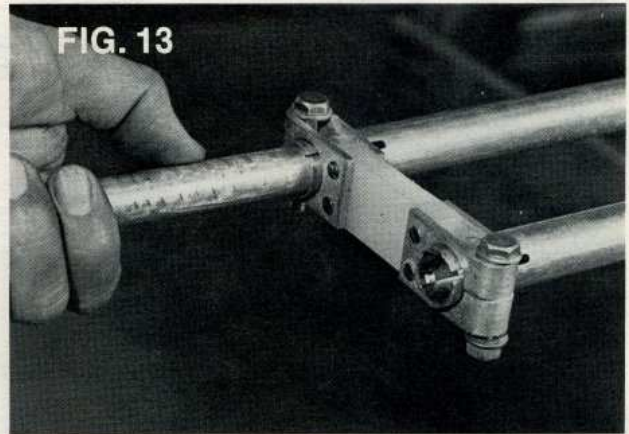

**FIG. 13**

**STEP 12**

Lock the three 5/8 inch spreader arms in place by tightening the three tube clamps left loose in Step 11. (Fig. 11)

Keep clamps near the edge of the tube.

**STEP 13**

Tighten all hardware of the 3/4 inch Balun separator clamps which were installed in Step 10.

Take note that the Balun arm pairs are not twisted before tightening.

**STEP 14**

Slide a 5/8 inch Balun separator clamp on each pair of 5/8 inch Balun arms. There are three pairs. Install the same hardware as shown in Fig. 9. Do not tighten.

**STEP 15**

Install a small tube clamp on each of the three 5/8 inch spreader arms, on the end slots. Leave loose.

**STEP 16**

A total of nine 1/2 inch tubes with flattened ends are supplied. Six of them are 32 inches long and three are 28-1/2 inches long. Separate the long tubes from the short ones.

**STEP 17**

Take two long 32 inch tubes and slide a 1/2 inch Balun separator clamp onto them, approximately 7 inches from the tip (Fig. 14).

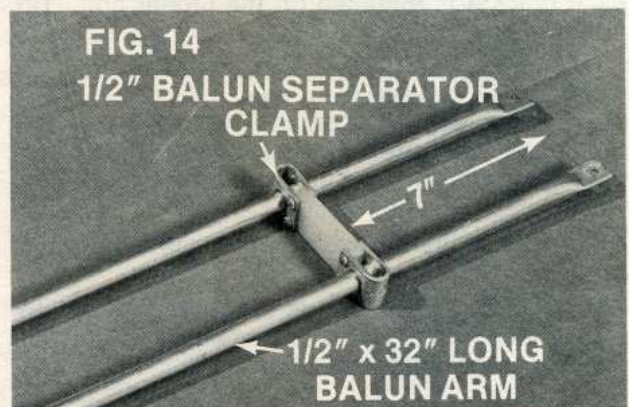

**FIG. 14**

**1/2" BALUN SEPARATOR CLAMP**

**1/2" x 32" LONG BALUN ARM**



### STEP 18

Attach this assembly to a pair of 5/8 inch Balun arms by sliding the pair of plain ends of the 1/2 inch tubes into a pair of 5/8 inch arms. (Fig. 15)

Make sure both 1/2 inch tubes are into the 5/8 inch arms up to the dimples.

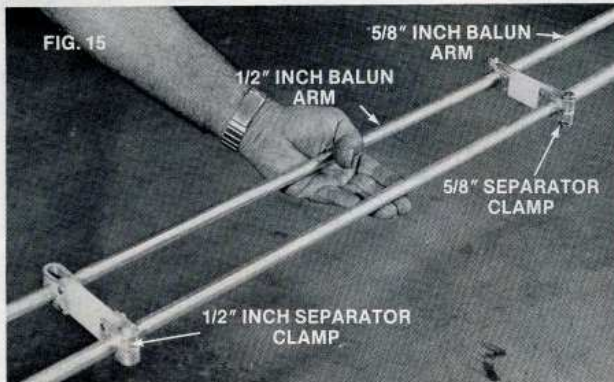

### STEP 19

Tighten the 5/8 inch Balun separator clamp, observing that the Balun arms are not twisted.

NOTE: Arrange the flattened ends so they are in the same plane as the hub.

### STEP 20

Install hardware and tighten the 1/2 inch Balun separator clamp 7 inches from the flattened tip. (Fig. 14)

### STEP 21

Repeat Steps 17, 18, 19 and 20 for the two remaining Balun arms.

### STEP 22

Take the three short 1/2 tubes (28-1/2 inches long) and insert each one into a 5/8 inch spreader arm, up to the dimple.

Tighten the tubing clamps after the flats have been aligned in the same plane with all the other flattened tips.

### STEP 23

Temporarily fasten the three Balun brackets with hardware as shown (Fig. 12A). It is important that each bracket is installed on the proper arm. Do not tighten.

### STEP 24

There are nine wire segments; six have lugs on both ends, these are peripheral wires. Three wires have a lug on one end only, these are the Balun wires.

Attach the six peripheral wires from one flattened tip to the other.

The same screw that holds the Balun bracket to the flattened tip is also the screw that will fasten one end of the peripheral wires.

Remove this 10-32 screw, pass it through the wire lug and replace.

Do not tighten. (Fig. 12A)

Every peripheral wire screw must be left loose until all six of the peripheral wires are attached. This will allow the wire lugs to naturally assume the proper angle.

See Fig. 12A & B for hardware placement.

### STEP 25

After the six peripheral wires are installed, tighten the nine 10-32 screws in the flattened tips holding these wires.

### STEP 26

Take a Balun wire which has one lug only and feed the plain end through the small hole in the center of the Balun separator clamp located nearest the flattened tips. (Fig. 16) Continue to pull wire toward the hub, feeding it through every Balun separator clamp.

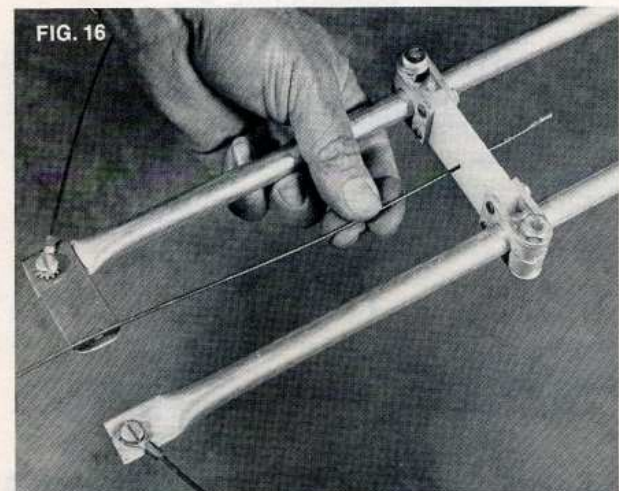

When the wire emerges out of the last Balun separator clamp, (clamp nearest the hub) it must be "strung" through the small cross drilled hole of a wire stud before it is fed into the terminal clamp. (Fig. 17) Aim the long end of the stud upwards. This stud will remain loose until a future step.

In order to facilitate feeding the wire into the terminator clamp, the two spacer bushings must be separated with your finger. This will expose a hole directly in the center of the terminator bolt in which the wire must be inserted. (Fig. 18)

Push the wire in just far enough so the lug at the opposite end of the wire lines up with the hole in the Balun bracket.

Fasten the wire lug to the Balun bracket with a 10-32 screw, two starwashers and a nut. (Fig. 19 & 12A)

Avoid kinking the wire.



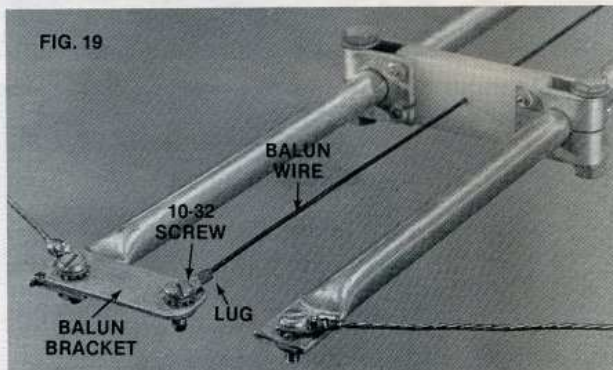
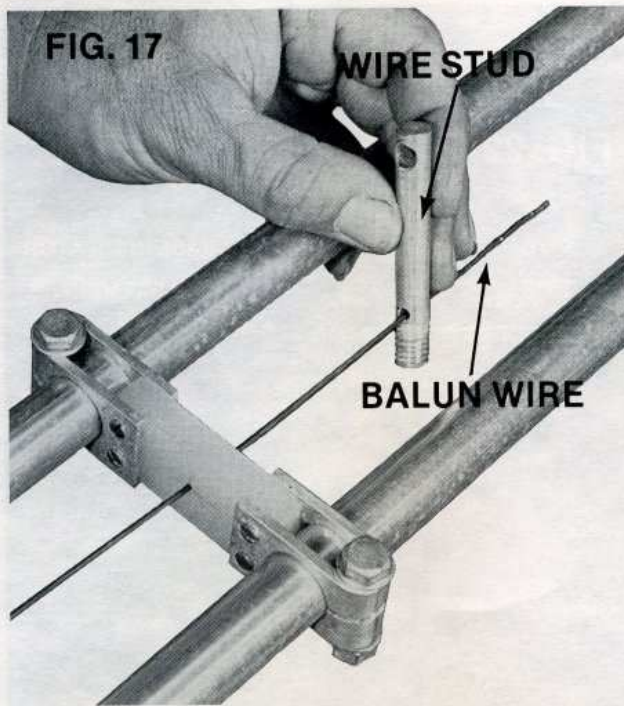

#### STEP 27

With a pair of pliers, clasp the wire where it enters the terminator clamp and push the wire into the clamp. Exert just enough force to straighten the wire. (Fig. 20)

While holding the wire in this condition with the pliers, tighten the terminator nut firmly with a wrench.

The wire should be securely clamped and not be able to be pulled out.

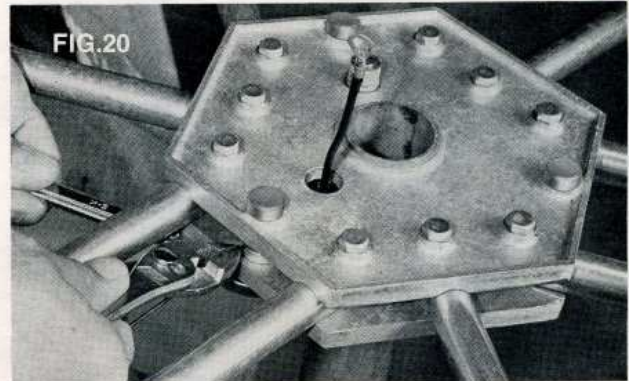

#### STEP 28

The two remaining Balun wires should be installed identically — Don't forget the wire studs.

At this point, the horizontal coax must be connected and the user will have to decide whether it will be easier to mount this assembly onto his supporting structure now, or if it will be to his advantage to finish the construction completely and mount the completed antenna **with the coax attached later**.

#### STEP 29

There are two methods of mounting this antenna to your mast. Choose Method A or B.

- A. It can be mounted directly on a mast which measures exactly 1.500 inches with a tube clamp supplied.
- B. If your mast is not exactly 1.5 inches outside diameter, but is between 1-1/2 inches and 1-3/4 inches, it must be side mounted as shown in Fig. 21.

Space the "H" brackets with their "U" bolts as far apart as possible on the mast support tube without placing the lower one on the slotted portion.

#### STEP 30

Feed your coax with a connector attached up through the mast support tube and affix it to the mating connector of the base insulator assembly. Tighten with pliers, do not rely on hand tightening alone. (Fig. 22)

**IMPORTANT NOTE:** Do not remove any of the screws from the insulator assembly while tightening the coax connector, otherwise the center wire inside the assembly will be twisted or broken.



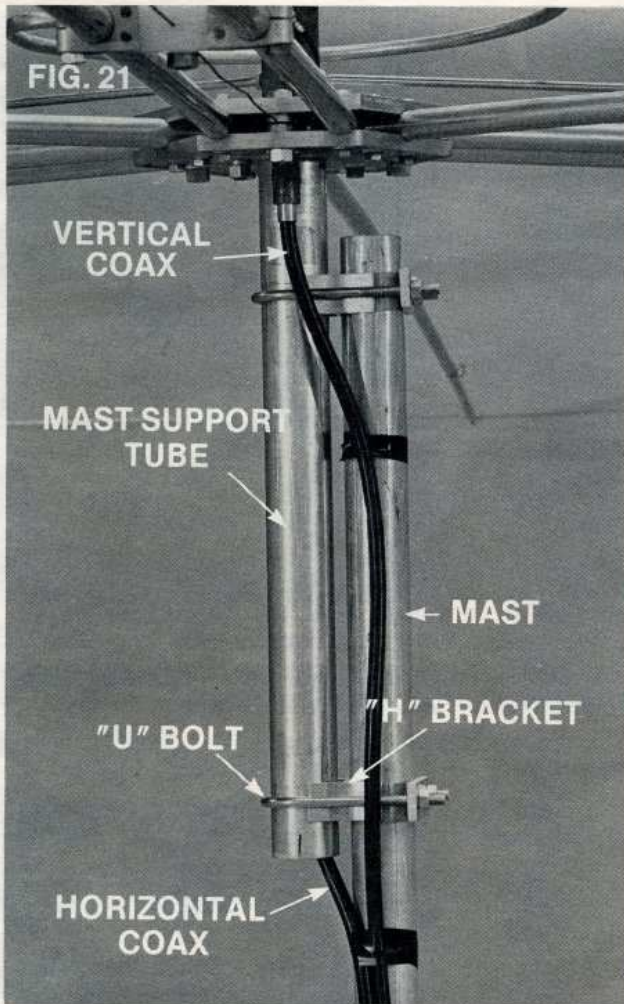

#### STEP 31

After the coax has been attached, then remove the bottom 1/4 inch screw and carefully push this assembly down into the mast support tube trying to keep the holes in alignment.

This hole from which the screw was removed must line up with one of the holes in the mast support tube located underneath the hub (Fig. 23).

The screw that was removed previously should now be threaded into one of the aligned holes. Install screws into the two remaining holes and tighten all three.

**NOTE:** If trouble is encountered starting the screw, it is probably because of hole misalignment. Take a small pointed object and align holes before inserting the screw. Do not use a wood object as it may break off in the hole.

#### STEP 32

Find the three feed rods. They are 1/4 inch solid aluminum rods about 2 feet long with threads on one end.

Screw 1/4 inch nuts on the three rods. The nuts must be threaded all the way onto the rods.

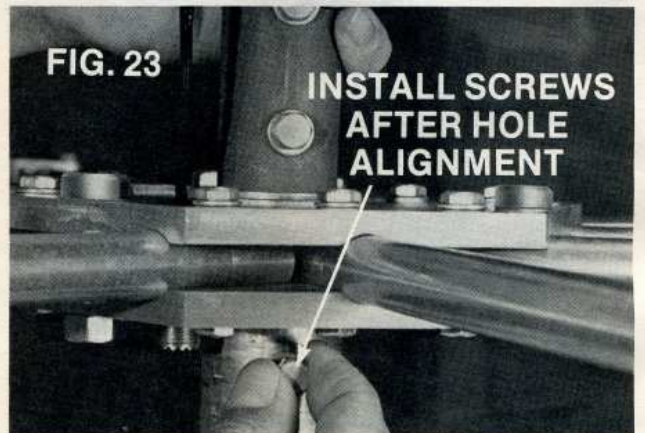
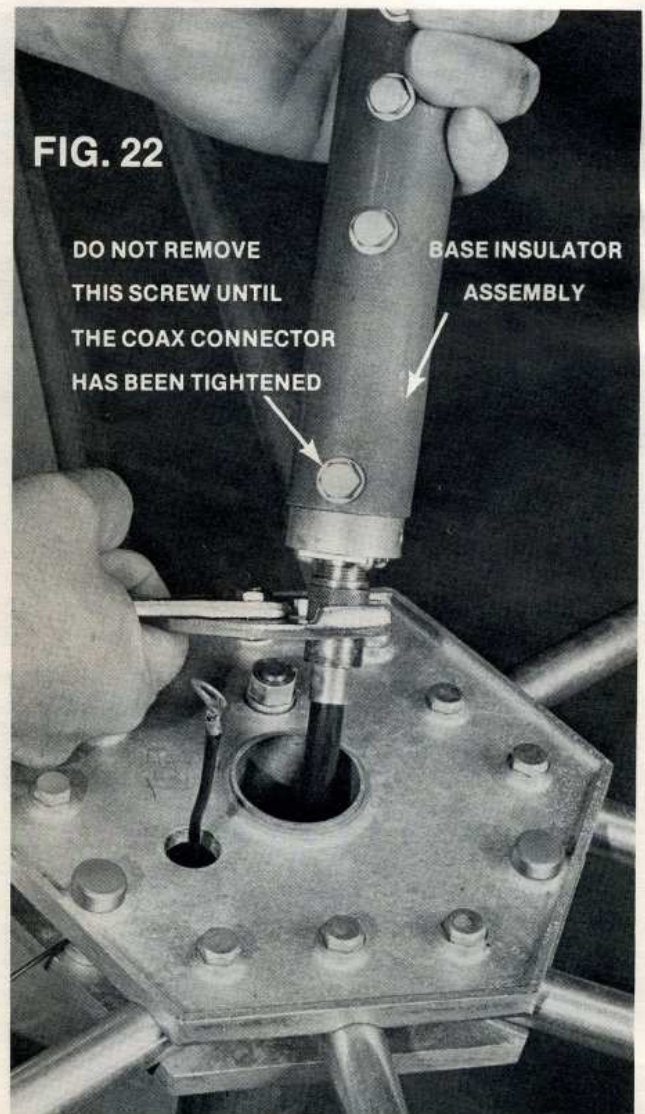

#### STEP 33

The base insulator assembly comes shipped with an alignment screw where one of the feed rods screw into.

Remove this screw and substitute a feed rod in its place. Leave loose. Install the other two feed rods in the holes which are in the same "circle". (Fig. 24)



### STEP 34

After the three feed rods have been installed, tighten the three nuts against the fiberglass base insulator tube.

### STEP 35

Loosen the hub lock nut. (Fig. 24) While holding the fiberglass insulator from turning, rotate the whole hub assembly until the three feed rods are lined up directly over the three Balun wires. Simultaneously Screw A of the insulator tube should be lined up with the 5/8 hole in the hub which contains the jumper wire. (Fig. 24)

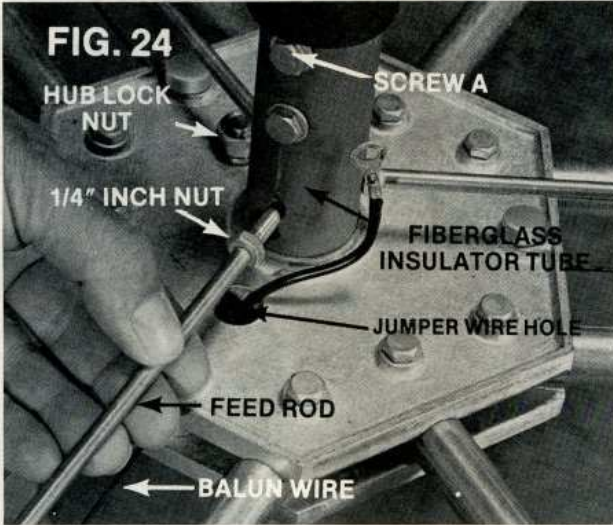

### STEP 36

The three 3/4 inch Balun separator clamps closest to the hub which were installed in Step 9 must be loosened and slid further away from the hub in order to facilitate connecting the wire stud to the feed rods. (Fig. 25)

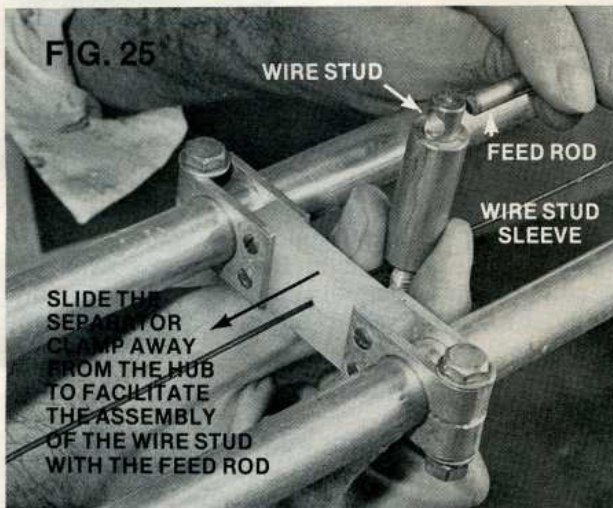

### STEP 37

Put a wire stud sleeve over one of the three wire clamp studs which were installed in Step 26. Push the sleeve on as far as possible so that the hole in the end of the stud is completely exposed. This stud is then slid onto the feed rod. (Fig. 25)

### STEP 38

Put a spacer bushing and a 3/8 nut on the threaded part of the stud and tighten 22-1/4 inches from the fiberglass insulator tube. (Fig. 26A)

The 22-1/4 inch measurement is from the outer surface of the fiberglass insulator tube to the center of the wire stud.

NOTE: When the 3/8 nut on the stud is tightened, the stud is locked to both the feed rod and the Balun wire simultaneously. (Fig. 26B)

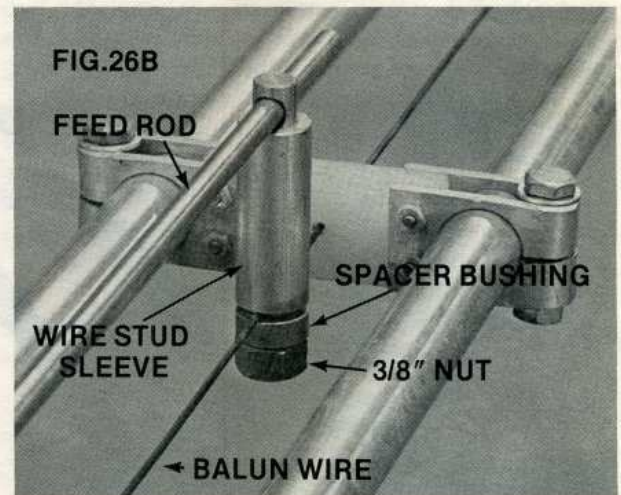
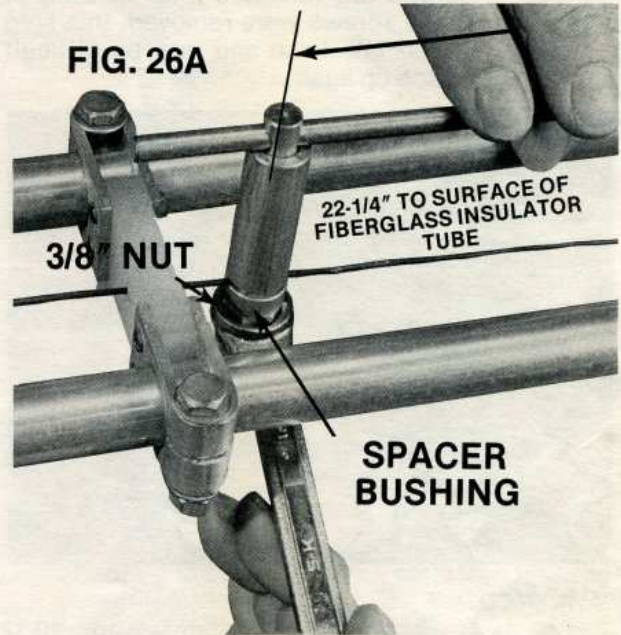

### STEP 39

The Balun separator clamp that was slid back to allow the installation of the wire stud onto the feed arm should now be repositioned and tightened 20 inches from the hub edge. (Fig. 9)

### STEP 40

Repeat Steps 36, 37, 38 and 39 for the remaining two feed arms.



### STEP 41

Just above the three feed rods on the fiberglass insulator tube, you will find two holes 180 degrees apart with 1/4 inch screws installed at the factory.

Remove the screw closest to the jumper wire. Replace this screw in the same hole with the lug of the jumper wire attached. Do not tighten. (Fig. 27)

**CAUTION:** Do not remove both screws at the same time. There is a metal slug inside of the insulator tube which these two screws are threaded into. If both of these screws were removed, this slug would fall down and may be difficult to line up again.

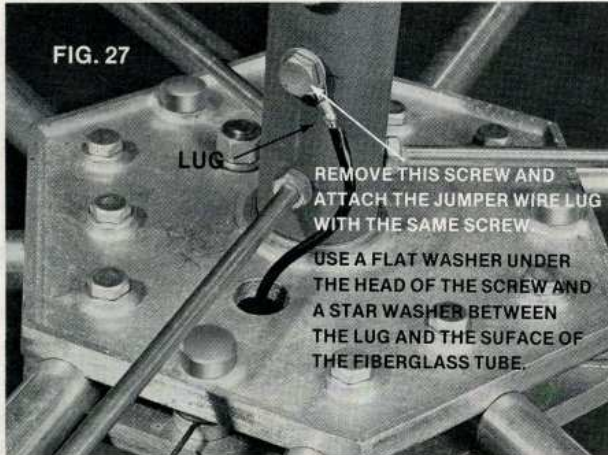

### STEP 42

Fasten the two hoop sections together with a 10-32 screw and nut. Use a starwasher between the two flat surfaces and another starwasher under the nut. (Fig. 28)

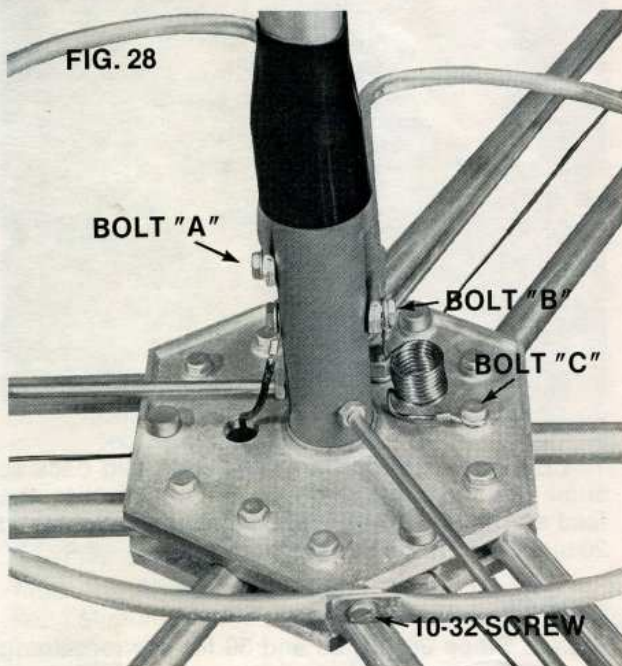

### STEP 43

Install the hoop and static coil to the fiberglass insulator tube as follows:

- Remove bolts A, B, and C (Fig. 28).
- Attach the hoop and static coil with the same bolts using the hardware shown in Fig. 29.

FIG 29

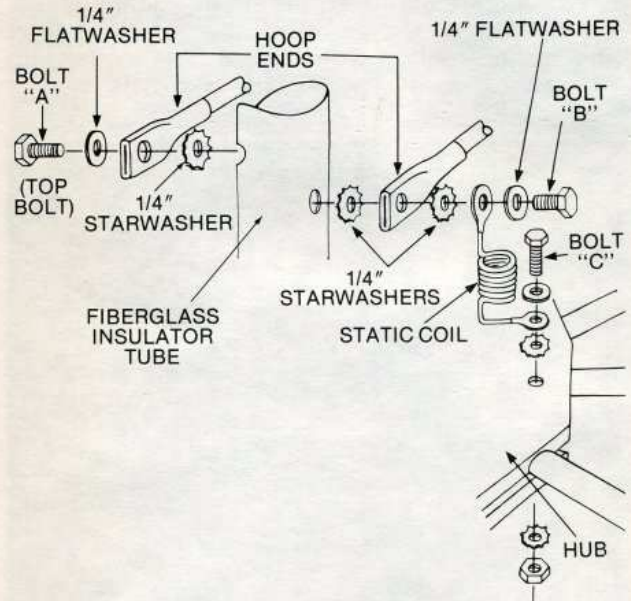

### STEP 44

Assembly of the vertical radiator (Fig. 30)

- Place the proper size tube clamp over the slotted end of each section of the vertical radiator. Start with the largest diameter section.
- Telescope all of the sections together. The sections will "bottom" against each dimple. Do not force beyond dimples.
- Position the edge of every tube clamp even with the edge of each slotted tube and tighten.
- Press plastic cap onto the tip of the vertical radiator.

### STEP 45

Place a tube clamp over the slotted portion of Tube G which is part of the base tube assembly (vertical tube projecting out of the fiberglass insulator tube). (Fig. 30)

### STEP 46

Take the vertical radiator assembly just completed in Step 44 and slide it into the end of the base Tube G described in Step 45. Slide radiator in up to the dimple and tighten clamp.



FIG 30

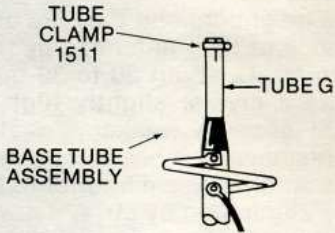
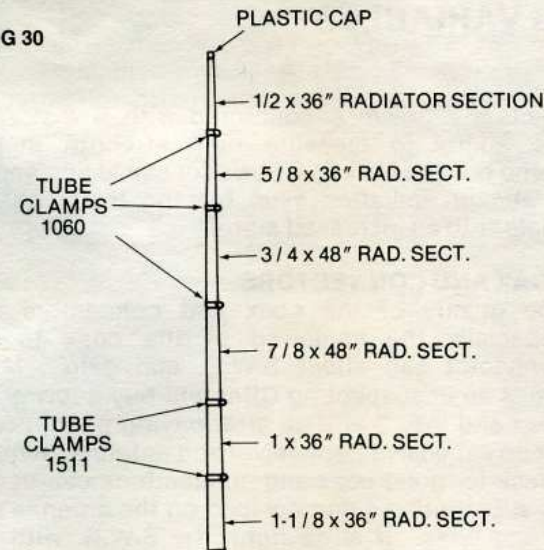

**STEP 47**

Route both coax cables to the switch box and attach the vertical coax (Fig. 21) to the connector marked V and the horizontal coax to the connector marked H. Connect a short cable from the switchbox to the radio. This short jumper may be RG 58 / U or RG 8 / U cable.

For best horizontal to vertical separation, the coax lengths should be 1/2 wave length multiples.

There are generally two types of coaxial cables in common use. One has solid dielectric and the other, foam dielectric. The dielectric portion of the coax is the plastic substance surrounding the center conductor.

If you are using solid dielectric coax, you should cut your length to multiples of 12 feet such as 12, 24, 36, etc.

If your coax is foam type, it should be cut to 14 foot multiples, 14, 28, 42, etc.

FIG. 31

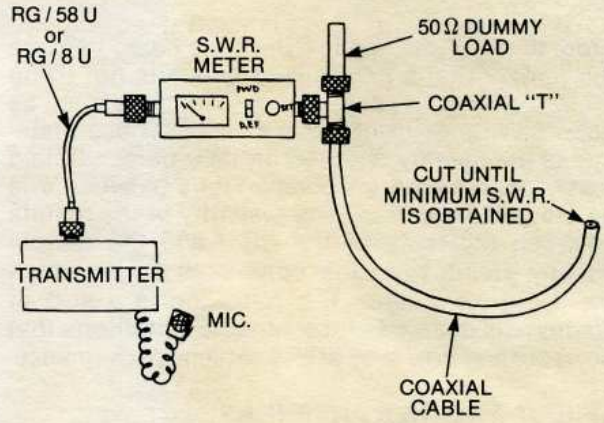

1/2 wave multiple lengths can be determined experimently by the following method if you have a radio transmitter, a S.W.R. tester and a 50 OHM dummy load. See Fig. 31 for proper hook-up.

- A. Connect a coaxial "T" to the antenna side of the S.W.R. tester.
- B. Connect a 50 OHM dummy load to one "leg" of the "T". NOTE: Do not use a dummy load with a built in light bulb.
- C. Take your coax cable, with a PL259 connector attached to one end only, and fasten it to the remaining "leg" of the "T". CAUTION: Be sure the far end of the coax cable is not shorted. Inspect carefully because the wire strands in the braid are very small.
- D. Connect the S.W.R. meter to the transmitter using a short length of 58U or 8U cable.
- E. Push the Mic button to transmit and check the S.W.R., the same as if you were checking the S.W.R. on your antenna.
- F. If the S.W.R. is low, (Meter Indication Low), advance the calibrate knob on the S.W.R. meter so the reflected reading is exaggerated. Leave the FWD. — REF. switch in the REF. position **ONLY** under this setting. **DO NOT SWITCH TO THE FWD POSITION BECAUSE THE METER WILL BE "PINNED" AND MAY DAMAGE THE MOVEMENT.** Adjust the calibrate control so the meter reads about mid scale. Take note of the meter reading.
- G. Cut a segment off of the "open" end of the coax. (The MIC button must **not** be depressed while cutting)
- H. Push the MIC button again and check the meter reading of this shorter length, and compare it with the previous reading. If the reading is better (lower), continue to cut off segments until the lowest reading is obtained. If the reading becomes worse the cable is already too short and a maximum of 12 to 14 feet will have to be removed before the proper length is achieved.



## ANTENNA TESTING VARIABLES

From time to time, many CBer's are heard to make the remark that a particular antenna is not living up to the advertised performance figures such as gain, S.W.R., or front-to-back ratio. These statements are usually founded on their personal field tests; often based on comparisons between one antenna and another. The disparity in the results between the tests of the CBer and the factory usually stems from the conditions under which the tests were run. The following is a sort of discussion of some of the variable conditions that do occur and how they affect antenna performance.

### EFFECT OF OTHER ANTENNAS

When two antennas are mounted near each other (even if they are used for different frequencies), a coupling usually results which in some way alters their operation. This coupling is even more pronounced when the antennas are mounted less than one wavelength apart. So, if another antenna is less than 36 feet from your CB antenna, there is a good chance that it changes its performance in some way.

### THE EFFECT OF METAL STRUCTURES

Not only antennas, but water towers, power lines, buildings, or any material of a metallic nature has the ability to misdirect transmission. Sometimes these obstacles will act as directors and sometimes as reflectors — causing the signal to increase or decrease in the intended direction.

Complaints of poor front-to-back ratio or lower than expected gain can usually be traced to this above circumstance — especially in beam-type operation.

### SIGNAL INTENSITY

The signal strength of a remote transmitting station can never be assumed to be of the same strength as in previous transmissions. Signals of incoming stations should be recalibrated to the antennas being compared. For this reason, you cannot take down one antenna, put up another one a week later, and expect to make accurate measurements. If the stations being used are using beam type antennas, a slight change in the beams' directions can also be critical. Contacts with mobiles are even less valid. A movement of five feet sometimes makes measureable differences in mobile communications.

### S METER CALIBRATION

Depending upon the CB set, an S meter is calibrated so that one S unit is equal to 6 db. Therefore, an antenna responsible for 1 S unit gain over another has also about 6 db gain over other antenna. Some S meters, however, are calibrated at only 3 db per S unit and others at 3 or 4 at the low end, and 6 or 7 at the top of the scale.

Another problem encountered with S meters is the ability to measure high strength inputs. Some bounce back at a powerful signal and appear erratic in operation even reading lower on the scale with an increased signal.

### COAX AND CONNECTORS

The quality of the coax and connectors and especially the soldering of the coax to the connector can affect S.W.R. and gain. Many times an unsuspecting CBer will buy a low grade coax and lose 2 or 3 db after paying good money for an expensive transceiver and antenna. A quick check for good coax and connections can be run by substituting a dummy load on the antenna end of the coax. If all is right, the S.W.R. with the dummy load should be a 1 to 1 match.

### CRYSTAL VARIATIONS

Mr. A. and Mr. B. are neighbors and they are comparing the performance of their antennas by their ability to transmit to Mr. C. about 20 to 30 miles away. If Mr. A. has a crystal slightly high on frequency, he might show a weaker signal to Mr. C. even though his operation has more power. This would make A's antenna seem inferior to B's. This problem can be eliminated by Mr. C's having a tunable receiver on his transceiver to match A's variation.

### TIME VARIATION

Any test of antennas should be performed with a time variation of about 15 minutes or less to eliminate variations due to tropospheric shifts and other changes that affect performance.

### GUY WIRES AND SUPPORTING STRUCTURES

Guy wires should preferably be of the non-metallic type using ski tow rope or other plastic lines. If metallic guy wires are used, they should be broken up at uneven intervals along their length to avoid interference and possible high S.W.R. In many cases, a manufacturer intends his antenna to be mounted on a metal mast or tower and in some cases, the mast or tower is used as a radiating element.



## PROPER CONSTRUCTION

If they could, manufacturers would ship all antennas fully assembled in order to eliminate mistakes in construction often found in antenna installations. Even the best instructions are sometimes misread and an antenna condemned only because of an error in assembly. If an antenna does not perform up to par, contact your local distributor or dealer, and if he can't help you, call the manu-

facturer. Chances are that somebody will get it working.

These are by no means all of the possible variations to consider in antenna measurements, however, they are some of the most important and understanding them will certainly be to the CBER's benefit and may save time in finding a trouble source.

## LIMITED WARRANTY

AVANTI warrants all products manufactured by it to be free from defects in material and workmanship under normal use. This warranty shall apply only to defects appearing within one year from date of purchase. This warranty also does not extend to damage caused by misuse, abrasion, corrosion, negligence, accident nor shall it apply to any item which shall have been altered in any way so as to affect its use and operation.

In the event the products manufactured by AVANTI are found to be defective in workmanship or material, AVANTI will repair or replace free of charge such defective material if delivered freight prepaid within the above stated one year period to the factory at 340 Stewart Avenue, Addison, Illinois 60101, with proof of purchase and if found by AVANTI's inspection to be truly defective in workmanship or material.

AVANTI's liability and the purchaser's remedies hereunder are exclusively limited to the repair of such products if defective or the replacement thereof. If inspection of any such products by AVANTI does not disclose any defect in workmanship or material, or if in the opinion of AVANTI the damage was caused by conditions beyond AVANTI's control, repair or replacement will be made at a reasonable charge.

AVANTI does not assume responsibility for loss or damage in transit to products returned for inspection.

On any product returned for inspection or replacement, freight charges to AVANTI must be paid by the purchaser. AVANTI will return all repaired or replaced goods freight prepaid.

THE FOREGOING WARRANTIES ARE EXCLUSIVE, AND ARE IN LIEU OF ALL OTHER WARRANTIES (WHETHER WRITTEN, ORAL OR IMPLIED), INCLUDING BUT NOT LIMITED TO THE WARRANTY OF MERCHANTABILITY IN OTHER RESPECTS THAN EXPRESSLY SET FORTH ABOVE AND THE WARRANTY OF FITNESS FOR A PARTICULAR PURPOSE. EXCEPT AS HEREIN PROVIDED, EVERY FORM OF LIABILITY FOR DIRECT OR CONSEQUENTIAL DAMAGES OR LOSS IS EXPRESSLY EXCLUDED AND DENIED.

Some states do not allow limitations on how long an implied warranty lasts, so the above limitation may not apply to you. Some states do not allow the exclusion or limitation of incidental or consequential damages, so the above limitation or exclusion may not apply to you.

This warranty gives you specific legal rights, and you may have other rights which vary from state to state.

69010677



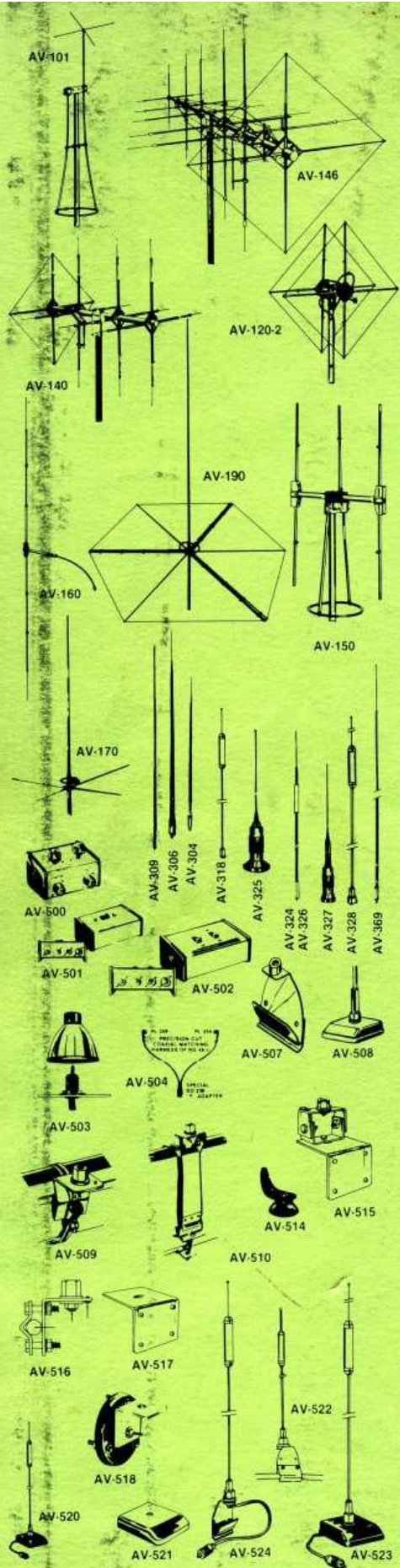

**AV-101** ASTRO-PLANE Base Station, 4.46 db, over Isotropic  
**AV-120-2** PDL II "Orbital Gamma Match" And AV-501 Switchbox, Dual Polarity  
**AV-130** STACKING KIT For 2 AV-120's Complete With Harness (Not Illust.)  
**AV-140** MOONRAKER® Base Station With Switchbox, 14.5 db, over Isotropic  
**AV-146** MOONRAKER® 6 Base Station With AV-502 Switchbox, 17 db over Isotropic  
**AV-150** ASTRO BEAM Base Station, 40 db Front to Back, 11 db over Isotropic  
**AV-160** RAMROD Multi-Purpose Base Station (Tunable 27-170 MHz)  
**AV-170** SIGMA 5/8 Base Station — Full 5/8 Wave Length, 5.14 db over Isotropic  
**AV-190** SATURN — Combination Vertical and Horizontal Omni Directional Base  
**AV-304** 4' Fiberglass RACER with Tunable Tip  
**AV-306** 6' Fiberglass RACER with Tunable Tip  
**AV-309** 96" Fiberglass RACER Whip  
**AV-318** 18" MINI-FAZER  
**AV-324** 4' HIPPO Top Loaded Mobile Antenna — 250 Watts Maximum Power  
**AV-325** 6' HIPPO Base Loaded Mobile — 500 Watts Maximum Power  
**AV-326** 6' HIPPO Top Loaded Mobile Antenna — 350 Watts Maximum Power  
**AV-327** RACER 27 Base Loaded Mobile With Spring, High Durability Tunable Whip  
**AV-328** 48" FAZER Top Loaded Mobile  
**AV-369** GATOR-WHIP (Tunable 25-40 MHz)  
**AV-500** 500 Watt AVANTI Matchbox  
**AV-501** CS-1 Coaxial Switchbox  
**AV-502** CS-2 Coaxial Switchbox For Use With Standby Antenna  
**AV-503** RACER 1/2" SNAP MOUNT With Standard 3/8-24 Thread  
**AV-504** Co-Phasing Harness For Installation Of 2 Mobile Antennas  
**AV-506** 3/8-24 Adapter For Use With AV-521's Or Other Trunk Mounts  
**AV-507** Gutter Clip 3/8-24 Thread Mount  
**AV-508** AV-506 Installed In AV-521 No-Hole Trunk Lid Mount  
**AV-509** Bumper Strap Mount For Compact Cars 3/8-24 Threads  
**AV-510** Bumper Strap Mount For Standard Cars 3/8-24 Threads  
**AV-514** Suction Cup Tie Down — No Tools Necessary For Installation  
**AV-515** Camper Mount With 3/8-24 Threads — Fold-Down Feature  
**AV-516** Truck Side Mounted Mirror Bracket With 3/8-24 Threads  
**AV-517** Camper Bracket Mount With 1/2" Hole For AV-327  
**AV-518** Thumb Screw Fold-Over Camper Mount  
**AV-519** Thumb Screw Camper Mount  
**AV-520** 18" MINI-FAZER With No-Hole Trunk Mount  
**AV-521** No-Hole Trunk Lid Mount  
**AV-522** 18" MINI-FAZER With Gutter Clip  
**AV-523** 48" FAZER With No-Hole Trunk Mount  
**AV-524** 48" FAZER Top-Loaded With Gutter Clip  
**AV-526** 4' HIPPO Mirror Mount Co-phase Package

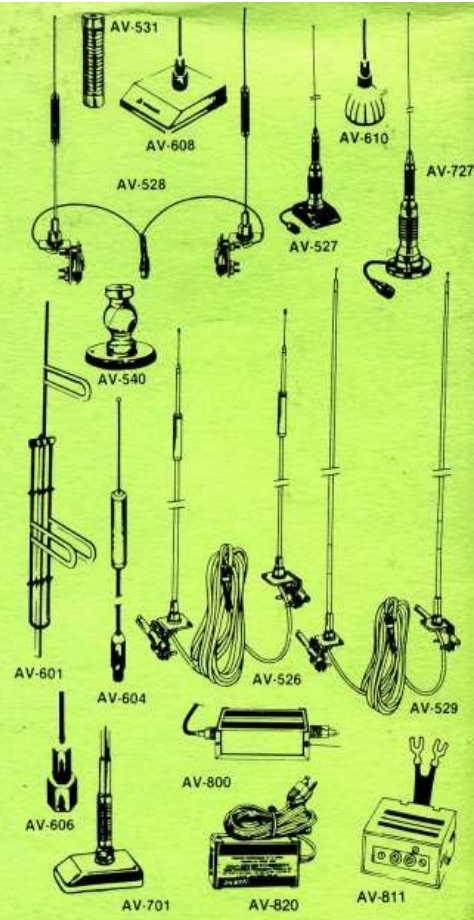

**AV-527** AV-327 With AV-521 No-Hole Trunk Mount  
**AV-528** 48" FAZER Stainless Steel Top-Loaded Mirror Mount Co-phase Package  
**AV-529** 4' Fiberglass RACER Mirror Mount Co-phase Package  
**AV-531** Rubber Shock 3/8-24 Threaded Medium Duty Spring  
**AV-535** Dual 18" MINI-FAZER With Gutter Clips  
**AV-537** RACER 27 Thumb Screw Camper Mount  
**AV-540** Cast Aluminum Swivel Ball Mount 3/8-24 Thread  
**AV-601** 25-50 & 140-174 MHz Base Station Monitor (Dual Banded)  
**AV-604** 25-50 & 140-174 MHz Mobile Monitor 3/8 Thread (Dual Banded)  
**AV-606** Same as AV-604 With AV-506 Mount And 17' Coax  
**AV-608** Same as AV-604 With AV-508 Mount And 17' Coax  
**AV-610** Same as AV-604 With AV-503 Mount And 17' Coax  
**AV-701** Special PROTECTIVE SPRING For AV-304's, AV-306's, and AV-328's.  
**AV-727** RACER 27 Magnetic Mount Base Loaded Mobile With Spring  
**AV-800** Low Pass TV Interference Filter  
**AV-811** CB Signal Rejection Filter, 27 MHz  
**AV-820** A.C. Line Filter  
**PK120** PDL (AV-120) Power & Gain Kit Also Adds 1 db Gain For Older PDL's!

ASTRO-PLANE, PDL II, ASTRO BEAM, RAMROD, SIGMA 5/8, SATURN, RACER, FAZER, MINI-FAZER, HIPPO, GATER-WHIP, INTERCEPTOR, are AVANTI trademarks.

**avanti**<sup>®</sup>  
 AVANTI RESEARCH AND DEVELOPMENT, INC.,  
 340 Stewart Avenue, Addison, IL 60101